

flexible roller bearings

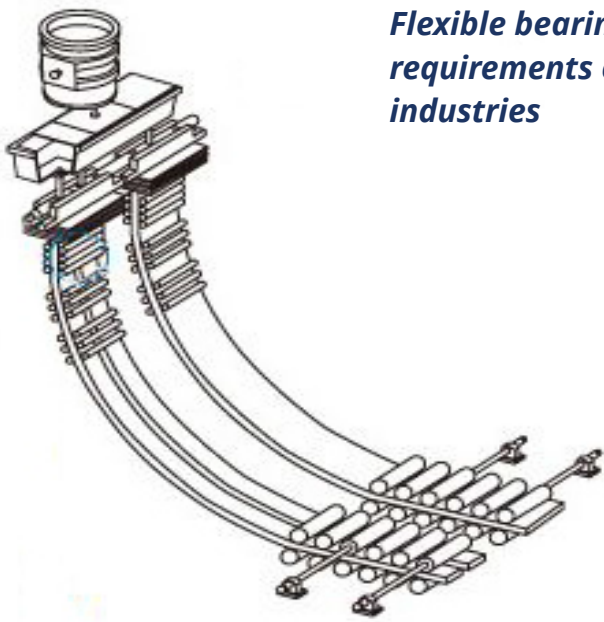

01 FLEXIBLE ROLLER BEARINGS



Flexible bearings meet requirements of Steel Mill industries

Applications

- Hot Rolling mills
- Pigcast Conveyors
- Continues casting rolls
- Conveyor furnaces

Components

- Spring inner ring
- Spring outer ring
- Solid roller cage / Flexible roller cage
- Thrust / Side ring

Material

- Wear resistant quenched and tempered steel to ensure long life

Advantages

- Sustains high temperature
- Heavy shock load
- Ease of filling and dismantling
- Compact design
- Low sensitivity to dirt

For more details of the size range and any technical questions feel free to contact us at sales@bmibearings.com



BEARING MANUFACTURING INDIA

